

Standing frames *Therapeutic indications*

THERAPEUTIC SIGNIFICANCE

Standing at an upright position allows the patient to return and get used to a normal position after being bedridden for a long period. For keeping an upright position, the body must exert some forces which are different from the ones he is used to exert when dealing with just a bed or a wheelchair. Thus, a relief can be obtained, decubitus pathologies can be prevented as well as using some articulations which are generally never put into action. One more accomplishment is setting the diaphragm free, which favours breathing.



“There are no precise indications as to the duration and frequency of use required to experience specific benefits from using these tools. Most studies refer to a 30-45 minutes use per day. However, it appears that those who can stand up for 1 and half hours per day can benefit from a great improvement regarding secondary complications. It would therefore appear that the minimum recommended time may be 30 minutes.”

Graduating Thesis by Amon Rambaldini, Master in “Assistive Technology – Aids for the Wider User Base”. University of Trieste – Academic Year 2003-2004.

HEALTH BENEFITS

- Reduces the decubitus sores ;
- Reduces the risk of venous return deficit;
- May reduce spasticity of lower limbs;
- Helps prevent retraction of the muscles of the lower limbs;
- Helps keeping the bone trophism;
- It stimulates the cardiovascular system;
- It improves the diaphragm breathing capacity;
- It improves function of the intestine;
- Reduces the risk of loss of sense of vertical position.

The pictures do not correspond fully to the new available configurations. Please see in detail the new choices available.

PSYCHOLOGICAL SIGNIFICANCE

One's position is a way of expression. Communicating from an upright position has a deeply positive significance.



PRACTICAL SIGNIFICANCE

The Standing frame with independent mobility by means of a joystick allows quick transferring, without the need of a carer's intervention. Once the upright position is reached, many daily-routine activities can be done. It is possible to perform movements on flat surface. It becomes easy to reach work tops to make use of them. Learning a specific technique according to the user's physical conditions, enables the user to perform many things without the presence of a carer.

6



STANDING FRAMES

Standing frames *An overview on options and adjustments*

A strong link between Struzzo's performance and its adjustments has emerged as a key aspect to the success of this standing system. This essential condition, which is not negative in itself, becomes critical if one thinks they can use and fully appreciate Struzzo without having first adjusted it to the user's body, or that they can adjust it without fully understanding what they are actually doing. Thus, adjusting the standing system to the person's anthropometric characteristics is the first and most important operation to do. It may only be done by an adequately skilled operator. A wrong adjustment limits or even hinders the use of the device.

Chinesport standing frames outstand for their easy tool-free adjustment feature which makes this operation fast and easy to carry out sometimes even by the end user.

THE SERVICE TRAY:

Available in two different sizes and of several materials. Its tilt can be adjusted.

THE STRUCTURE – UPPER PART:

It can be dynamic, to accompany the user during the lift, or fixed with great variety of possibilities for adjusting it in height and depth.

THE SIDE HANDLES:

They may be short for easy access or long for greater restraint capacity. They can be adjusted independently in width by sliding or simultaneously by rotating at the same time.

LIFT SUPPORT:

Available in two versions: harness or seat with different lengths. The seat is adjustable in its depth.

LIFT:

The upright position mechanism can be fully powered by electrical motor or partially aided by a gas spring.

THE HEIGHT OF THE STRUCTURE:

Adjustable by means of an electric motor or a gas spring to be easily adapted to the anthropometric characteristics of the user.

THE KNEE SUPPORTS:

Available in an anatomic version, with greater support or more flexible and soft with the possibility of little displacements of the knee. They are adjustable in height, width, depth and rotation.

THE FOOTPLATES:

They can be made of metal, adjustable in depth, with possibility to apply heel rests too. They can also be made of wood, positionable in depth with screws.

THE BASE STRUCTURE

It can have an electric drive with limited encumbrance, easy to deal with, or a version with greater accessibility. Alternatively It is also available a version with aided mobility and great accessibility.



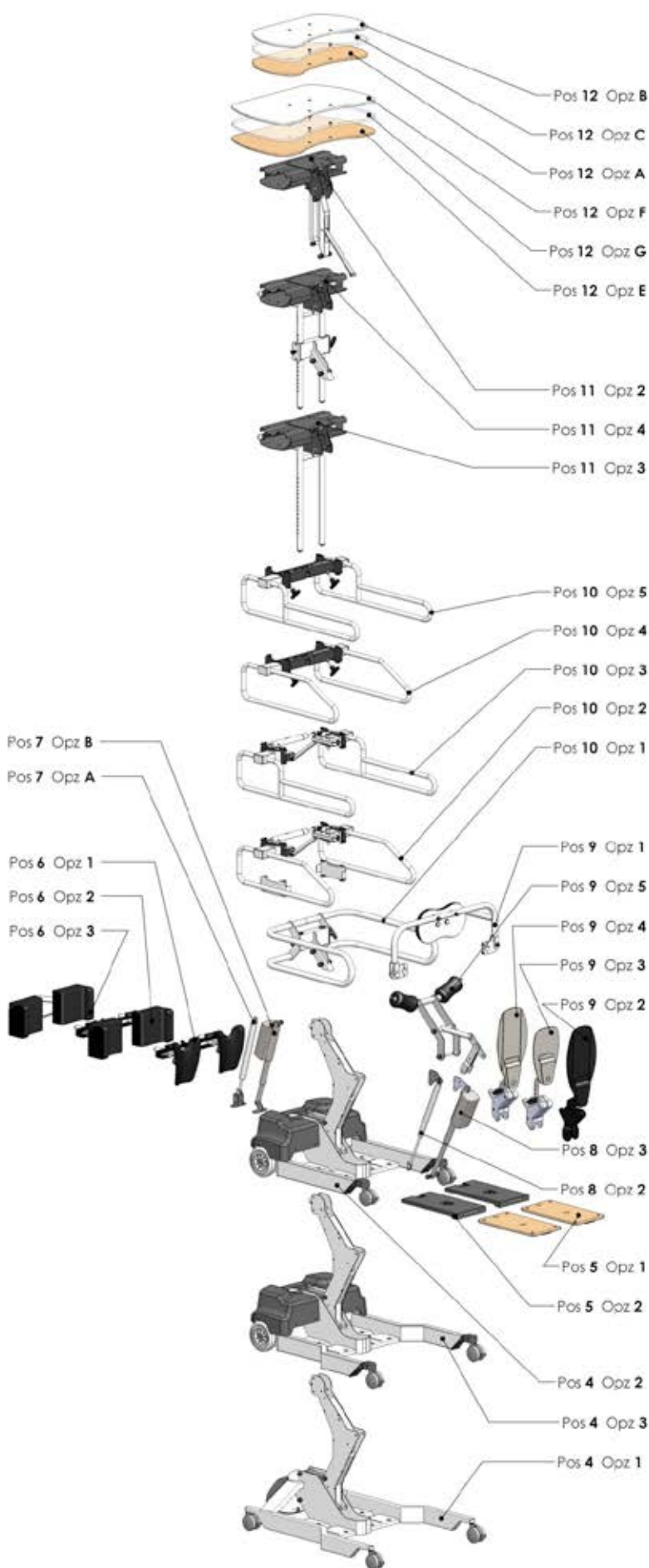

The Chinesport standing frame can be configured in the best way to meet the specific needs of the end user. Every position of the product code has its own specific meaning, with different available options, and therefore there is always the possibility to show a preference. The choice of the options determines the base characteristics of the product. Along with the options, there are also the accessories which moreover contribute to improve the comfort, accessibility and for greater support and safety. Accessories can be purchased at a second moment as well.

FIXED			TO BE CONFIGURED									
A	V	3										
1	2	3	4	5	6	7	8	9	10	11	12	

POS.	CONFIGURABLE	AVAILABLE OPTIONS
4	THE BASE STRUCTURE	<ul style="list-style-type: none"> 1 - for aided mobility 2 - for independent mobility, compact base 3 - for independent mobility, easy access
5	FOOTPLATES	<ul style="list-style-type: none"> 0 - without footplates 1 - wooden footplates, positionable with screws 2 - metal footplates, adjustable in depth
6	KNEE SUPPORTS	<ul style="list-style-type: none"> 0 - without knee supports 1 - anatomic adjustable supports 2 - softer adjustable supports 3 - softer supports, adjustable only in height
7	HEIGHT OF THE STRUCTURE	<ul style="list-style-type: none"> A - adjustment by gas spring B - adjustment by electric motor
8	Lift	<ul style="list-style-type: none"> 0 - unaided, manual 2 - partially assisted by gas spring 3 - fully assisted by electric motor
9	Lift SUPPORT	<ul style="list-style-type: none"> 1 - no support 2 - fixed long seat 3 - short seat, adjustable in depth 4 - removable long seat 5 - harness
10	SIDE HANDLES	<ul style="list-style-type: none"> 1 - base handles, not adjustable 2 - short handles, adjustable by rotation 3 - long handles, adjustable by rotation 4 - short handles, adjustable by sliding 5 - long handles, adjustable by sliding
11	THE STRUCTURE - UPPER PART	<ul style="list-style-type: none"> 2 - dynamic structure, adjustable handles 3 - fixed structure, fixed handles 4 - fixed structure, adjustable handles
12	SERVICE TRAY	<ul style="list-style-type: none"> 0 - without service tray A - wooden service tray - medium size B - polyethylene service tray - medium size C - plexiglass service tray - medium size E - wooden service tray - large size F - polyethylene service tray - large size G - plexiglass service tray - large size

Standing frames Configuration guide

Position 4

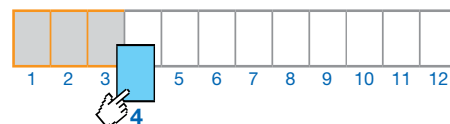

THE BASE STRUCTURE

It is a horizontal structure, as a base support, for the user to transfer onto. There is a column inserted into this base which can be integrated with an upper part in order to allow the user to adopt and keep an upright position. The column is built in a certain form so as to offer an important point of reference for the knee rotation axis. There are different systems for lifting and supporting the patient which are presented below as configuration options. The base structure enables movements of the user in an upright position, unaided or assisted by a relative or a carer.



1 Aided mobility version

The base frame and the steel column are coated with epoxy powder which stand on four swivelling wheels for hand pushing indoors assisted by a carer or a relative. The wheels have a diameter of 75mm with standing brakes. The base has an easy access, i.e. maximum internal width is 630 mm, to allow the approach with a wheelchair. The vertical central element, integrated with an adjustment system (see available options in position 7 of the article code), can vary in height in a range of 200 mm. Thus, the reference with the column, to be aligned with the knee rotation axis can vary in height from a minimum 365 mm to a maximum of 565 mm referring to the base. Dimensions: Width 752 x Length 1035 mm x Height 675 – 875 mm. Maximum load: 140 kg



2 Independent mobility version, compact base

The base frame and the steel column are coated with epoxy powder which stand on two motorized driving with a diameter of 150 mm front wheels, and two back swivelling wheels with a diameter of 75 mm with individual brakes. The base is compact, not big in size to enable the final user to easily move indoors unaided. The internal width to access the aid is 466 mm. The vertical central element, integrated with an adjustment system (see available options in position 7 of the article code), can vary in height in a range of 200 mm. Thus, the reference with the column, to be aligned with the knee rotation axis can vary in height from a minimum 365 mm to a maximum of 565 mm referring to the base.

The user can move around using a joystick to set speed and direction of the aid. He can, unaided move around on a surface with a slope up to 2 degrees and overcome steps of up to 20 mm and obstacles of 30 mm. The aid offers a working time of 2,5 hours with a battery recharge time of 8 hours. The maximum speed established as default is 2,5 km/h. Dimensions: Width 595 mm x Length 905 mm x Height 675 - 875 mm. Max. Load: 140 kg



JOYSTICK FOR CONTROL IN THE INDEPENDENT MOBILITY VERSIONS

In the electric-motor driven versions, the control joystick can be adjusted to obtain the best ergonomic positioning for the user. The joystick can be adjusted in width of 200 mm and in depth of 60 mm. it can also be placed at both sides of the service tray. The metal support structure of the joystick can be adjusted in rotation with a margin of position up to 460 mm. this means that the user can use the joystick even from a different sitting position, i.e. being able to move the aid from his own view range when sitting on a sofa or bed.

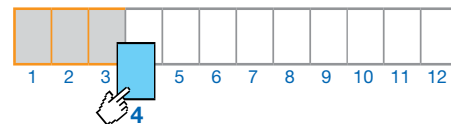

THE BASE STRUCTURE



3 Independent mobility version, easy access

The base frame and the steel column are coated with epoxy powder which stand on two motorized 150 mm diameter front wheels, and two swivelling wheels of 75 mm with independent brakes. The base features easy access, i.e. the internal maximum width is 630 mm to enable the approach of a wheelchair. The vertical central element, integrated with an adjustment system (see available options in position 7 of the article code), can vary in height in a range of 200 mm. Thus, the reference with the column, to be aligned with the knee rotation axis can vary in height from a minimum 365 mm to a maximum of 565 mm referring to the base.

The final user moves around on the device in an upright position autonomously as described in option 2. He can, unaided move around on a surface with a slope up to 2 degrees and overcome steps of up to 20 mm and obstacles of 30 mm. The aid offers a working time of 2,5 hours with a battery recharge time of 8 hours. The maxim speed established as default is 2,5 km/h. Dimensions: Width 752 mm x 1055 mm long x 675 - 875 mm height. Max. Load: 140 kg



CHINESPORT
Manuals & Movies
Cultura

02011.DVD STRUZZO
The video shows examples of the use during daily life at home and at work.



The video shows some examples of use of the aid called Struzzo in daily life. The user moves around unaided at home and at work. The possibility of an electrically servo-assisted base is now a configuration choice.



Standing frames Configuration guide

Position 5

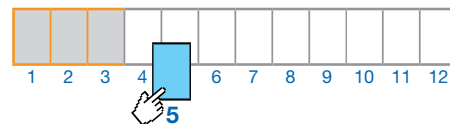

THE FOOTPLATES

After the initial approaching phase it is necessary to transfer the person onto the device. The user is typically on a seating position to start and moves his feet onto the footplates of the frame, either by himself or assisted by the carer. These footplates represent, therefore, the first point of contact between the person and the standing aid and the access to it can be simplified by the possible adjustment of the depth of the footplates. The footplates can be adjusted or placed at different positions by sliding independently moving towards the user, reducing thus the distance from the plates themselves. The foot, once on the plate, does not encounter any obstacle and therefore it is possible to proceed by progressive movements or by sliding until the second point of contact is found, that is to say, the knee supports. The base footplates can be made of wood or metal with different characteristics and ways of adjustments. There are some accessories available for the metal footplates.

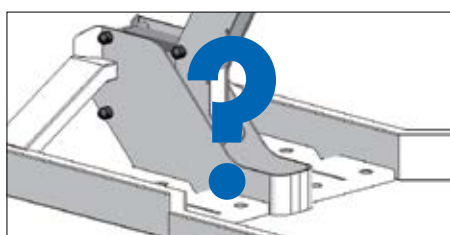

0 Without footplates

Choosing this feature means to express a preference for the making of personalized footplates by a technician or any other specialized personnel close and at the service of the end user. Max. load: 140 kg

No accessories available.

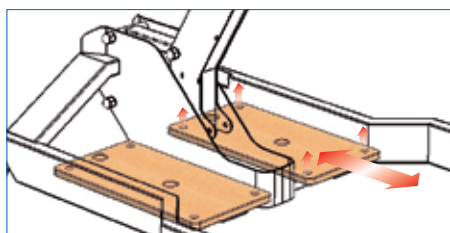

1 Wooden footplates, positionable with screws

The footplates are made of plywood birch panels, painted dull transparent and they are applied on a metal base structure. These plates can change position regarding depth by means of screws to be fixed with. Height of the base with the plates on is of 67 mm to the underneath surface. Wood can be the best choice when it is necessary to make adjustments, personalizations, or even special supports to be applied on the plates for the best footrest of the user. This type of modification can be done only by an on-site specialized orthopedics laboratory. Another property of the wood is its greater comfort for the user who may wish to put his feet on the plates barefoot, as for example when transferring onto the standing frame when getting up from bed. Dimensions: Width 200 mm x Depth 380 mm x Thickness 18 mm; Footplate Weight: 3,6 Kg. Max. load: kg 140

No accessories available.

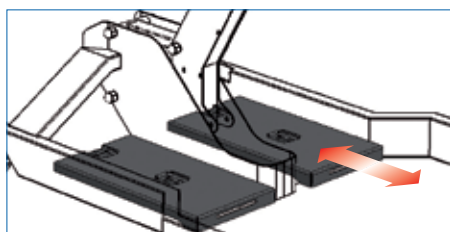

2 Metal footplates, adjustable in depth

On the other hand, metal footplates can be chosen applied on the same base structure. These plates can be immediately adjusted in depth without using any tools up to a maximum of 100 mm. These footplates have the special feature of enabling the application of some accessories such as the heelrests available with a fix version code AC0685, or adjustable in width code AC0686. When heelrests are set, it is possible to apply some straps for fixing the foot to the stand. Dimensions: Width 200 mm x Depth 380 mm x Thickness 18 mm; Weight 4,9 Kg. Max. load: kg 140

POSSIBLE ACCESSORIES:

AC0047 foot straps, AC0685 fixed heelrests, AC0686 adjustable heelrests

Position 5

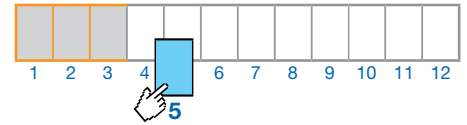

6

THE FOOTPLATES



FOR AN EASY ACCESS:

Metal footplates, adjustable in depth independently and immediately allow to reduce the gap between the base of the frame and the user either on a wheelchair or seated. This improves accessibility and makes it easier for the positioning of the feet onto the aid.

ACCESSORIES FOR METAL FOOTPLATES



AC0047 FOOT STRAPS

To stabilize the feet on the plates. They can be used only with the adjustable heelrests accessory code AC0686. Available in pairs.



AC0685 FIXED HEEL RESTS

It is a guidance for the user once he is on the device. They offer a back support for the feet with a height of 25 mm. They can be used only with metal footplates. Available in pairs.



AC0686 ADJUSTABLE HEELRESTS

Both plates can be adjusted in their width independently. Each heelrest can be used with a foot strap for stabilizing the foot on the plate code AC0047. The heelrests are 25 mm high from the foot plates. They are available in pairs.



ADJUSTMENT OF THE HEELRESTS

Each heel rest can be adjusted independently for up to 90 mm accessory code AC0686 and with a center distance minimum 206 mm and maximum 386 mm.

Standing frames Configuration guide

Position 6

KNEE SUPPORTS

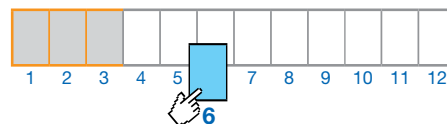

The person involved in the procedure of standing up from a sitting position with the aid of a Standing frame finds at knee level an important point of reference and support. When feet are already set on the footplates, and the first important phase for transferring onto the device is completed, the user must get to touch the knee rests, which must have been adjusted adequately at an under knee joint level for the maximum support and for allowing the knees to move freely while the user is lifted. Taking into consideration this is an important point of contact, support and partial unload of the weight of the user during the procedure of coming upright, several types of support have been developed, regarding shape, material and possible adjustments.

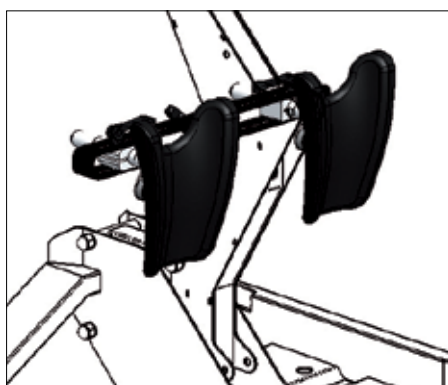

1 Anatomic supports, adjustable

These supports are made of foam polyurethane, shaped and anatomic. They partially surround laterally the knee for a better stability. They are applied to a metal horizontal structure, which enables an adjustment by hand of each support regarding width from 210 a 380 mm or depth from 100 mm and in rotation up to +/- 20 degrees. The height adjustment of both supports is simultaneous and follows the principal height adjustment of the entire frame. Such variation can be as up to 200 mm regarding the base of the aid.

A second intervention by hand can be done for adjustments at its specific support height of up to 40 mm which allows to adjust them to be in line with the knee rotation axis. It is possible to use some accessories for these supports, such as leg straps code AC0014 to prevent a hyperextension of the knee and for a greater stability at knee level.

Dimensions of the support: width 500 mm x depth 310 mm x height 160 mm; weight: 3 kg

POSSIBLE ACCESSORIES:

AC0014 Leg straps

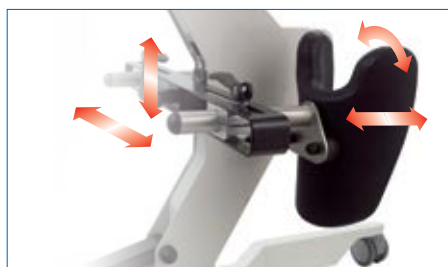

THE ORIGIN OF THE ANATOMIC SUPPORT

This type of support is the result of a chalk cast of a user's knee, who having complained about pain in that area, has proposed the making of a more anatomic solution, which will obviously be placed at an under knee joint level.



The picture above does not fully correspond to the new configurations. Please see for example the now available options for the service tray.

Position 6

KNEE SUPPORTS

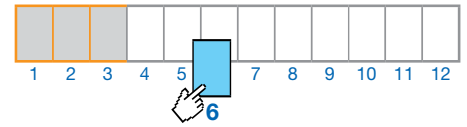

6

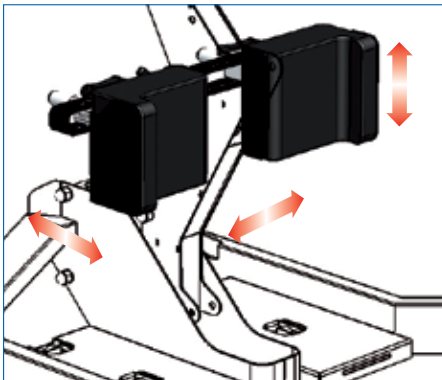

2 Softer supports, adjustable

These are alternative supports, softer, padded, made of foam and with removable synthetic leather cover. As in the previous described option these supports can be applied to a metal horizontal structure, which enables an independent adjustment by hand of each support regarding width or depth as well a simultaneous adjustment in height. The structure is clearly suitable for holding and fixing this other form of padded supports which are available by default in black synthetic leather. It is possible to order as accessories the same adequate supports with different colours than the original synthetic leather.

Dimensions of supports: width 550 mm x depth 310 mm x height 160 mm. weight: 4,2 kg

POSSIBLE ACCESSORIES:

AC0014 Leg straps, AC0689.W ? Coloured padding for knee supports

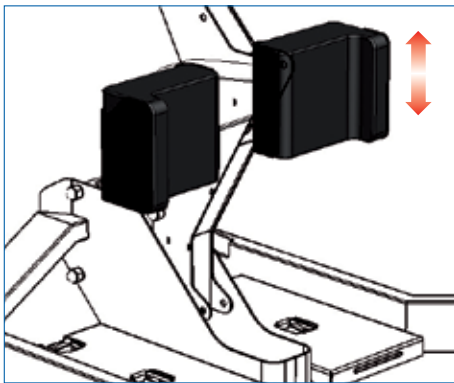

3 Softer supports, adjustable only in height

These are soft supports, padded made of foamed material and synthetic leather removable upholstery as the ones of Option 2, but they are not adjustable neither in width nor in depth because in this case these adjustments are not considered essential. They are adjustable only simultaneously in height. These supports can be applied to a metal structure suitable for holding and fixing this other form of supports. As in the previous examples, these are available by default in black synthetic leather, but it is possible to choose as accessories similar supports of different colour.

Dimensions: width 480 mm x depth 235 mm x height 160 mm; Weight: 3,6 kg

POSSIBLE ACCESSORIES:

AC0014 Leg straps, AC0689.W ? Coloured padding for knee supports

ACCESSORIES FOR KNEE SUPPORTS



? CHOOSING THE COLOUR OF THE PADDING

It is important always to specify the colour code for the upholstery along with the chosen article if the option is available.



AC0689.W ? COLOURED PADDINGS

These are made of soft foamed material with synthetic leather upholstery. The padding is applied to the specific metal structure. Available in three colours. Available in pairs.



AC0014 LEG STRAPS

These enable a greater stabilization of the lower limb when the user is standing on the device. The strap is applied at the level of the knee supports. Available in pairs.

Standing frames *Configuration guide*

Position 7

HEIGHT OF THE STRUCTURE

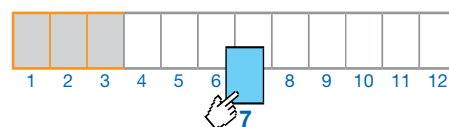

The adjustment in height of the main structure is one of the most important adjustments of the standing frame so that it can fit the anthropometric characteristics of the end user. The standing frame is easily adjustable to the height of the person due to the possibility of setting it by means of gas springs or electrically. This adjustment can be easily done by the user, unaided even when he is already in the upright position. Therefore, as a result of this adjustment the whole system of supports to the knee, side and chest are changed in position for more safety and comfort.

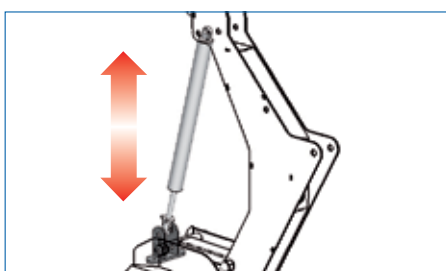

A Height of the structure, gas spring adjustment

The adjustment of the whole main structure according to the height of the user is served by gas springs. The extensible mechanical device is governed by a lever to block the position,. It is placed on a side handle. The adjustment is performed with little effort and therefore the whole structure can be adjusted to persons who are very different in height. This options is suggested when the aid is intended to be used by the same person all the time at home, and after an initial setting may not be necessary to further do any adjusting except for little adaptments when necessary. Weight: 0,5 Kg. Max. load: kg 140



Control for adjusting the height of the whole structure with gas spring.

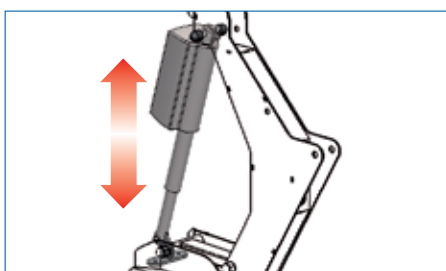

B Height of the structure, electric adjustment

In this case the adjustment in height of the whole main structure is done electrically by means of a battery-powered motor with a hand control. it is immediate and total effortless. The user or the carer can check the battery charge level by means of a display on the device. The recharge battery average time is 8 hours. This can be the best choice for a rehabilitation center or a community where the standing frame can be used by a group of persons also during the same day. Weight: 2 kg. Max. load: kg 140



Hand control with magnet for adjusting electrically the height of the whole standing frame.



The video shows a sequence of transfer and lift by a Chinesport standing frame with long seat. Some possible adjustments and available accessories are presented.



Position 7

HEIGHT OF THE STRUCTURE

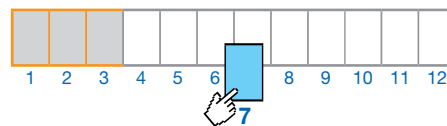

6



"... it certainly stands out in terms of functionality when it comes to the possibility of adjusting the supports under the patella and for the special seat which enables easy transfer even from low sitting positions such as sofas."

Giliola Manica
Rovereto (Trento) - Italy
Spinal cord injury at D5-D6 - 32 years old

She has been on a wheelchair due to motorbike accident. She is an INAIL (Italian National Institute for Insurance against Accidents at Work) patient.



The picture does not correspond completely to the new configurations available. Please see new options at the specific paragraphs.

FOR EASY ACCESS:

If a seat is chosen as a support for lifting (see "Lift support" - referring to position 9 of product code) during the transferring phase from the wheelchair to the standing frame, the seat can always remain horizontal and be aligned to the sitting plane of the user because the height of the aid has been adjusted. Such alignment of the seat at a starting point can simplify and increase safety while the accessing to the aid. The user may transfer himself from his bed or from the sofa with this type of further simplified accessibility.



Standing frames Configuration guide

Position 8

LIFT

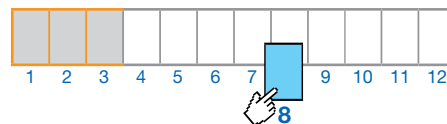

If necessary, to compensate reduced mobility of users who are not able to create or stand the strength and movements for lift, the structure of the standing frame can be set with different assisting systems. It can be fully served by an electric motor or partially assisted by a system of gas springs. Once the choice is taken about the technical characteristics, for partial or total aid it will be necessary to choose the proper support for the person during the lift and considering his movement capabilities. Thus, the available options are presented at the following position 9 of the configuration code.

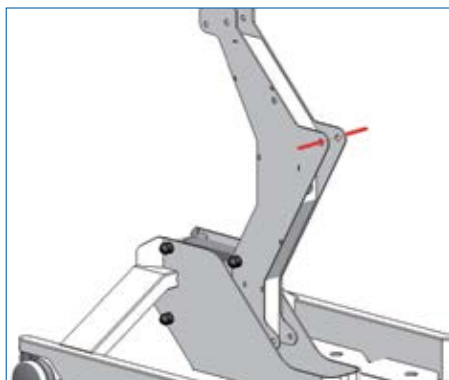

0 Unaided lift, manual

In this situation the person is capable of lifting himself unaided, using his own strength or he has little strength but valid and continuous assistance is provided by a relative or carer. Lift is done manually and the user can hold on to the side handles and to the service tray. If the user is not capable of coming up by himself he must be aided by one or more cares according to his body weight.

Max. weight: 140 kg

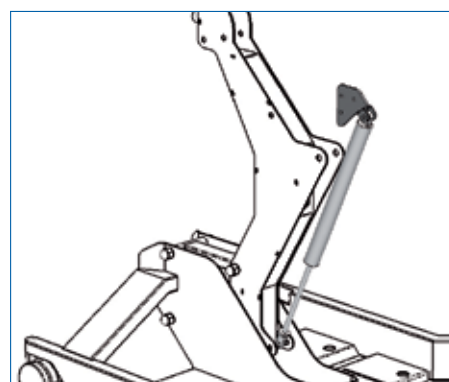

2 Partially assisted by gas spring

This system ensures a push from underneath the support of the person all along the lift process. This push is provided by a gas spring which partially reduces the weight of the user while rising. The user can interrupt the movement towards the upright position at any time, thus the mechanism is blocked and holds the patient at the position already reached. The ergonomic lever control is positioned on one of the handles and it allows the user to unlock the spring. The eventual descent is slow and pushed downward by the weight of the patient. The position of the control can be modified. The support, can also be provided with a special flat standard or long seat. See details in the following Position 9 of the product configuration code.

This standing aid can be used by weak but careful and sufficiently coordinated users who are able to transfer themselves unaided from their wheelchair to the standing aid seat, but who are unable to lift by themselves. It can be a valid alternative considering price and performance if compared to a fully manual lifting, i.e. carried out fully by the user or carer. Weight: 0,9 kg; Max load: kg 140;



Lever control for servoed lifting by gas springs. The other lever shown in the picture is the one for adjusting the height of the structure with a second gas spring.

"An important advantage offered by this standing aid compared to similar ones is the sense of accomplishment felt by users as they can use it unaided. This feeling is obviously not experienced with motorized lift models or when the carer provides significant help." Dr. Paolo Rispoli, Rehab Specialist - april 2006



Position 8

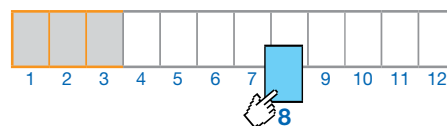

LIFT

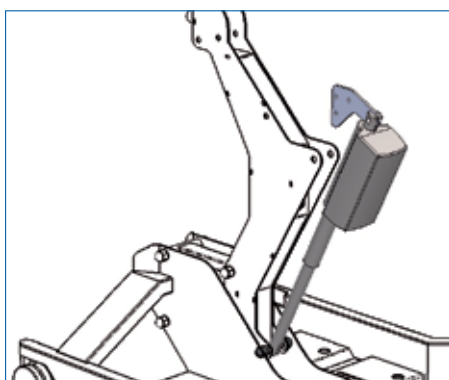

3 Fully assisted by electric motor

In this situation the user is fully aided during lift. The electromechanical extensible device, which is under the support of the person, is governed by hand control, which allows to stop the movement while lifting at any time. The end user can therefore make a pause at an intermediate position between sitting and standing before completing the lift. Both the user or carer can easily check the charge level of the battery by means of a display on the aid. Batteries need 8 hours to be fully recharged and the charge is enough for 30 complete cycles from a sitting to an upright position and viceversa with a user who weighs not more than the recommended weight established. An acoustic overload indicator is provided as well. Max User weight: 140 kg; Weight: 2 kg.



Hand control with magnet for fully aided lift.



A POSSIBLE DEVELOPMENT IN THE NEED OF ASSISTENCE

Whenever the capabilities of the user may diminish in time, it is possible to modify the standing frame from manual to an assisted one. It is, therefore, possible to modify in a subsequent moment after the purchase a base structure into a partially or totally assisted one; either with gas spring or electric motors. This intervention, however, must be done at the Chinesport site or it must be carried out by authorized and specialized personnel only.

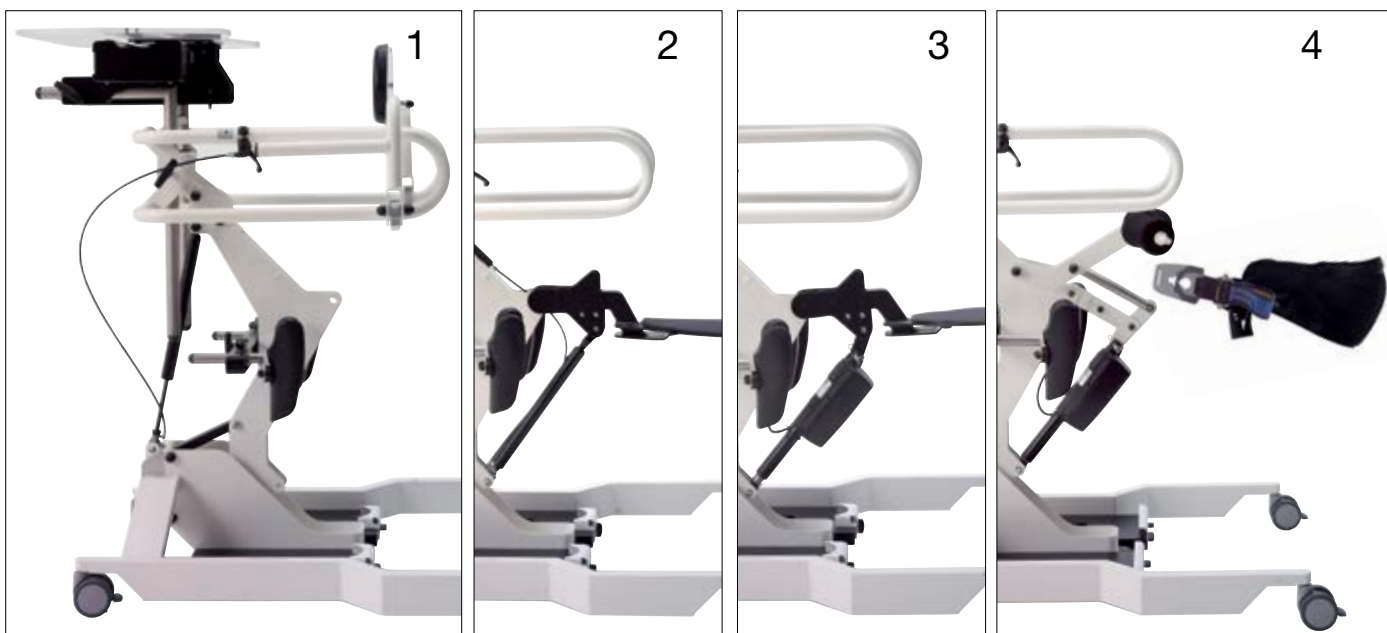

1
Lift: manually
(position 8, option 0);
Support: only final restraint
(position 9, option 1)

2
Lift: partially assisted
(position 8, option 2);
Support: fixed long seat
(position 9, option 2)

3
Lift: fully assisted (position 8,
option 3);
Support: fixed long seat
(position 9, option 2)

4
Lift: fully assisted
(position 8, position 3);
Support: with harness
(posizione 9, opzione 5)

Standing frames Configuration guide

Position 9

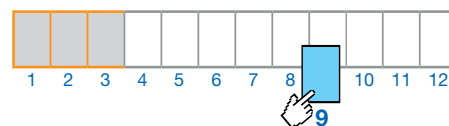

LIFT SUPPORT

Each user has specific assistance needs while transferring onto the standing frame and then to reach the upright position. Therefore, we offer different support solutions for each need. Especially, when the user does not cooperate, or is not capable of sitting stable, there is a traditional system for support and restraint with a harness, which avoids transferring the patient onto the structure and allows to begin the lifting from the wheelchair. Otherwise, a system with a seat is offered, which better reproduces the dynamic of the natural normal standing-up maneuver.

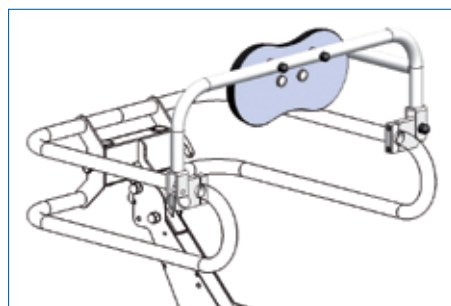

1 No support for lifting

It may not be necessary to have any support while coming to the upright position because the person is capable of transferring onto the standing frame from the wheelchair unaided and adopt the upright position. If this may not be so, one or more cares or relatives must assist the user. Once the upright position is reached, a safe restraining support is provided by a low-back support which can be closed down with an accessible handle and lock system. It may be necessary to have some help for the closing of the back rest. Dimensions of the back restraining support: With: 715 mm x Length/Depth: 305 mm x Height: 290 mm. Weight: 3,2 kg . Max. load: 140 kg.

No accessories available.



Rotation adjustment 90° (Open / Closed)

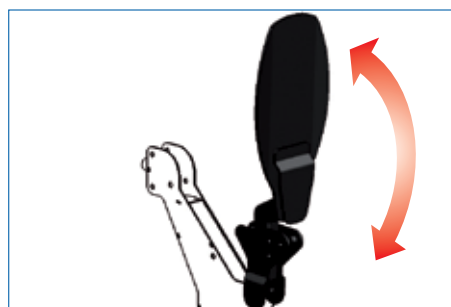

2 Long seat, not adjustable in depth

The seat is made of steel plate with epoxy powder coating, and it is applied to the base structure of the aid as a lift support. The elongated seat is designed to enable an easier transfer of the user from the wheelchair onto the standing frame, thus reducing or eliminating the gap distance between both. Therefore the seat is pushed from the bottom by a gas spring or by an electric motor assisting the user all along the process of coming to the upright position (see available options in position 8 of the article code). This mechanism holds the patient safely, having the possibility to stop at any half-way point for an eventual rest before reaching the upright position. The support can be eventually rotated for 90 degrees considering the knee rotation point.



Whenever the user is stable on the seat but not capable to help himself onto it from the wheelchair, a specific accessory, a "shaped pocket", can be used – code AC0048. In this case, the seat is inserted into the "shaped pocket" which has been previously placed under the anti-decubitus cushion of the wheelchair. The user, then, does not have to make any further movements. The user may be weak but careful and sufficiently coordinated. The seat is provided with a base padding. Dimensions of the lift and back restraint support: Width 202 mm x Length/Depth 587 mm x Height 142 mm. Weight: 4,5 kg. Max. load: 140 kg.

POSSIBLE ACCESSORIES:

- AC0048 Shaped pocket
- AC0544 Long seat padding

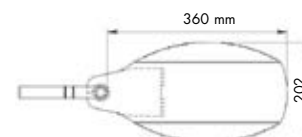

Position 9

LIFT SUPPORT

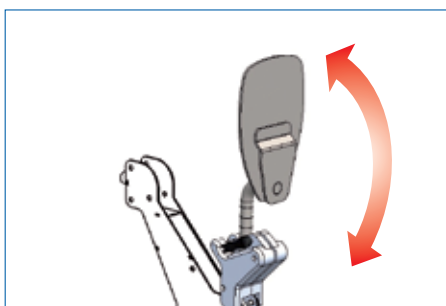
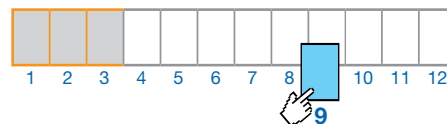

3 Short seat, adjustable in depth

The seat is made of stainless steel plate, and it is fixed to the base structure of the aid by a blocking device in aluminium. In this case the lift support is shorter, and it is adjustable in depth up to 120 mm. Possible adjustment of the support is 90 degrees regarding the knee rotation point. It is possible to stop safely the lift procedure at any time either by the user or a carer. A default base padding is included for the seat to avoid direct contact between the user and the seat. This type of seat is recommended when the user is capable of transferring with little help from the wheelchair onto the standing frame. Dimensions of the lift and back restraint support: Width 174 mm x Length/Depth 524 mm x Height 142 mm. Weight: 4,9 Kg. Max. load: 140 kg.

POSSIBLE ACCESSORIES:

- AC0543 Short seat padding
- AC0690 Adjustable long seat

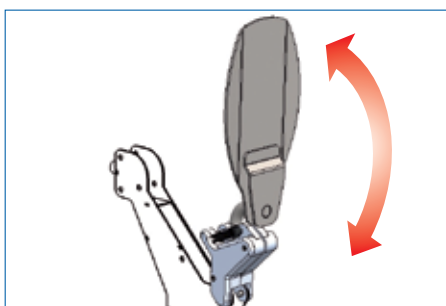
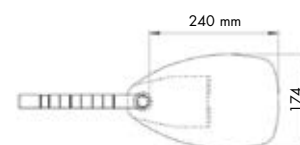

4 Long seat, removable

The seat is made of stainless steel plate, and it is fixed to the base structure of the aid by a blocking device in aluminium. The support seat is long, similar to the previously mentioned Option 2, but in this case, the seat is adjustable in depth as well. Thus, the possible adjustment of the support is of 90 degrees regarding the rotation point of the knee. The long shape of the seat can simplify the access to the standing frame that is to say, reduce the distance gap between the wheelchair and the aid. May the person not be capable of transferring onto the seat by himself, the "shaped pocket" accessory can be used. Dimensions of the lift and back restraint support: Width: 202 mm x Length/Depth 578 mm x Height 142 mm. Weight: 5,5 kg. Max. load: 140 kg.

POSSIBLE ACCESSORIES:

- AC0048 Shaped pocket
- AC0544 Long seat padding
- AC0691 Adjustable short seat

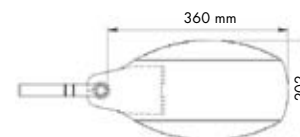

WHY IS THE SEAT CONFIGURATION PREFERABLE?

Traditional motorized standers apply a compression force on the femur axis at the beginning of the lift maneuver: this means that knees and hips are loaded while they are flexing, i.e. in a position that is not ideal for the load. That is why applying a load is unsuitable or even dangerous for people with osteoarthritis of the knees and hips, those with consequences of a hip fracture, those with severe femoral osteoporosis and those who have undergone replacement hip operations (sometimes prone to dislocation).

The standing aid with seat completely removes this compression force and is therefore particularly safe and comfortable.



Standing frames Configuration guide

Position 9

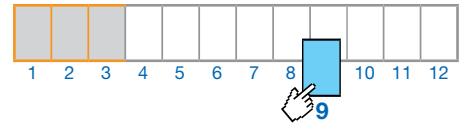

LIFT SUPPORT

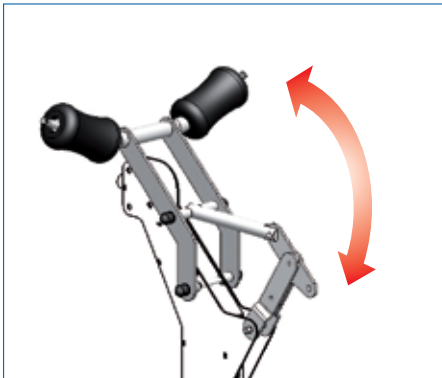

5 Harness support

Whenever the user is not very cooperative a folding steel arm with epoxy powder coating is applied onto the main base structure. This arm for lifting is designed to be used with a specific harness included. This system eliminates the possible problem of transferring from the wheelchair onto the aid. In this situation the user may not be so cooperative and need a restraint support as well while moving upwards. Dimensions of the support for lifting and back restraint: Width 490 mm x Length/Depth 410 mm x Height 380 mm. Weight: 4,1 kg. Max. load: 140 kg.

No accessories available.



FULLY ASSISTED LIFT

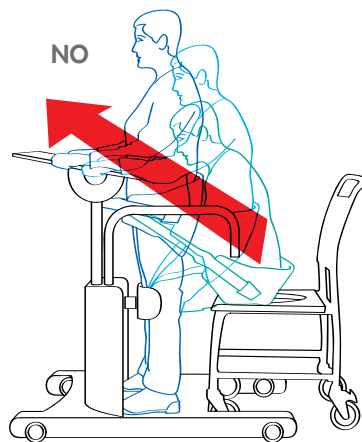

Traditional standing frames with harness may apply an oblique traction during the lift that creates a high compression on the user's femur and hip.

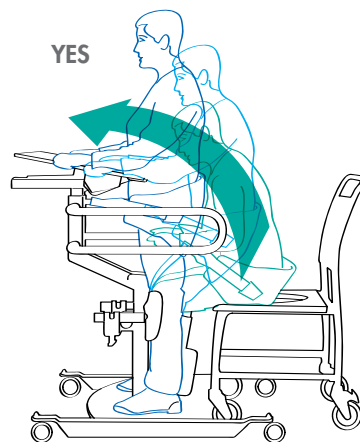

The harness lifting system has a variable geometry that ensures a relatively low compression on knee and hip joints.



STANDING FRAMES

ILLUSTRATION OF THE RESTRAINT SYSTEM

The harness is provided with an outer pocket that makes it easier for the carer to position it under the buttocks. A safe restraint of the user is ensured by the harness itself, which works as support when in the upright position.



Position 9 ACCESSORIES FOR COMFORT AND EASY ACCESS TO THE SEAT



AC0691 ADJUSTABLE SHORT SEAT
 The seat is 240 mm long, enough to hold the user safely while lifting. It can be adjusted in depth when applied to the locking device of the structure. Dimensions: Width: 174 mm x Length/ Depth: 524 mm x Height: 142 mm. Weight: 4,9 kg.



AC0543 SHORT SEAT PADDING
 It is breathable thanks to a unique combination of high quality materials, tested and certified. Easy to wash and sterilize, it offers great flexibility and comfort keeping its shape in time. It can be applied on the short adjustable seat, code AC0691.



Chinesport standing frames undergo important stress and safety tests, also carried out by other institution's laboratories. The video shows an important example of a load test on the special support seat for lifting.



AC0690 ADJUSTABLE LONG SEAT
 It is long to eliminate or reduce the distance gap between the user on the wheelchair and the standing frame. The seat is 360 mm long, and it can be adjusted in depth. Dimensions: Width: 200 mm x Length/ Depth: 578 mm x Height: 142 mm. Weight: 5,5 kg.



AC0544 LONG SEAT PADDING
 It is breathable thanks to a unique combination of high quality materials, tested and certified. Easy to wash and sterilize, it offers great flexibility and comfort keeping its shape in time. It can be applied on the long adjustable seat, code AC0690.



The video shows some of the available accessories applied on a configured model of the Stand Up series, for example the leg strap, the long seat padding and the special shaped pocket for an greater accessibility and easier transfer of the user from the wheelchair.



FOR EASY ACCESSIBILITY

AC0048 POCKET FOR LONG SEAT
 If the person is stable but unable to transfer unaided from the wheelchair onto the seat, a "shaped pocket", can be used. This special pocket can be an essential accessory if we want the user to have all the benefits of lifting with a seat, avoiding the initial difficulty of the problem that is transferring onto the standing frame. The user may be weak but careful and sufficiently coordinated.



APPLYING THE "SHAPED POCKET"
 The elongated seat is inserted into the shaped pocket placed under the anti-decubitus cushion, thus avoiding the direct transfer of the user onto the seat. It may be advisable that the user is watched or assisted by a carer if he is not strong enough to insert the seat into the shaped pocket.

Standing frames Configuration guide

Position 10

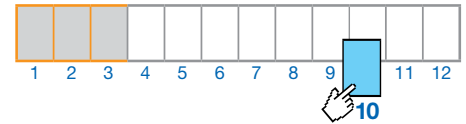

THE SIDE HANDLES

The standing frame features two side handles for safely restraining the user while coming to the upright position. This structure can be both for help and support, whenever the user is cooperative, during the lifting and until the stabilization in an upright position is reached. So, different types of handles have been designed, with different shapes and sizes; different ways of adjusting them and many possibilities of applying specific accessories and for a greater side and back restraint. At the same time, the main frame to which they are attached, can be integrated with other front restraining and support accessories to help the user if needed.

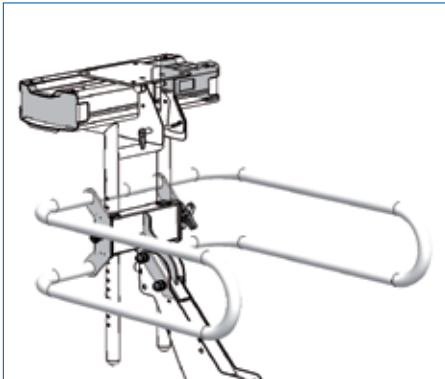

1 Base side handles, not adjustable

Steel frame for safely restraining the user while coming to the upright position and keeping stable. The side handles can be used also as a useful support in case the user lifts himself unaided. The width between the two handles is 542 mm and it is fix. This type of handle is recomendable for a user with a good control of the trunk and able to reach the upright position unaided or with just partial aid.

Dimensions: Width 598 mm x Length/ Depth 640 mm x Height 230 mm; Weight: 6,5 kg. Max. load: 140 kg.

POSSIBLE ACCESSORIES:

AC0044 Back strap; AC0692 Anti-crush system; AC0693 Front support; AC0694 Front support with anti-crush system

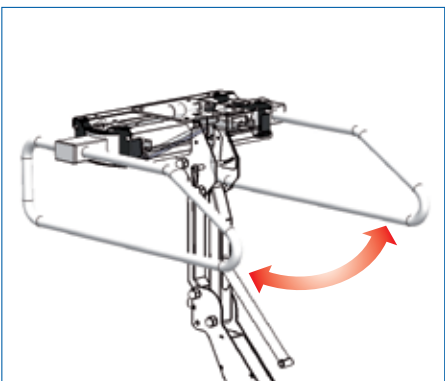

2 Short handles, adjustable by rotation

Main supporting frame with short side handles, adjustable in width for better restraint and to adapt better to the anthropometric characteristics of the user. The adjustment of the width of the handles is done by rotation and it is activated by means of a lever. The device is designed with a lock position function and it is controlled with a gas spring. The adjustment of the width is done simultaneously for both handles. Width between the handles can vary from a minimum 274 mm and a maximum 860 mm. Dimensions: Width 626 mm x Length/ Depth 655 mm x Height 230 mm; Weight: 6 kg. Max. load: 140 kg.

POSSIBLE ACCESSORIES:

AC0044 Back strap; AC0049 Lateral supports; AC0050 Lateral and back supports; AC0692 Anti-crush system; AC0693 Front support; AC0694 Front support with anti-crush system

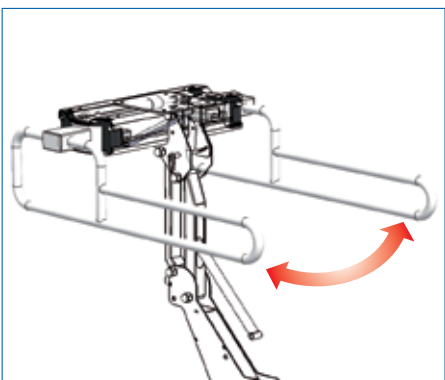

3 Long handles, adjustable by rotation

Main supporting frame with longer side handles if compared to the previous option, adjustable in width for better restraint and to adapt better to the anthropometric characteristics of the user. The adjustment of the width of the handles is done by rotation and it is activated by means of a lever. The device is designed with a lock position function and it is controlled with a gas spring. The adjustment of the width is done simultaneously for both handles. Width between the handles can vary from a minimum 194 mm to a maximum 964 mm. Dimensions: Width 626 mm x Length/Depth 802 mm x Height 230 mm; Weight: 6,9 kg. Max. load: 140 kg.

POSSIBLE ACCESSORIES:

AC0044 Back strap; AC0702 Adjustable Lateral supports; AC0703 Adjustable lateral-back supports; AC0692 Anti-crush system; AC0693 Front support; AC0694 Front support with anti-crush system

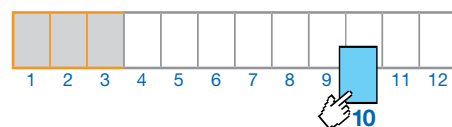

THE SIDE HANDLES

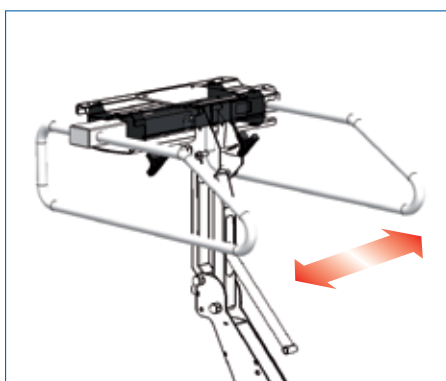

4 Short handles, adjustable by sliding

The main supporting frame is provided with side handles adjustable in width for better restraint and to better adapt to the anthropometric characteristics of the user. The adjustment of the width of the handles is done by sliding, and it is activated by a small lever which is also used for locking manually the position. Therefore the adjustment of width is done separately for each handle. The width between the two handles may vary from a minimum of 370 mm to a maximum of 580 mm. A special feature of these handles is that it is possible to rotate them inverting their position for a better side restraint for the trunk of the user. Dimensions: Width 460 mm x Length/Depth 655 mm x Height 230 mm; Weight: 5,4 kg. Max. load: 140 kg.

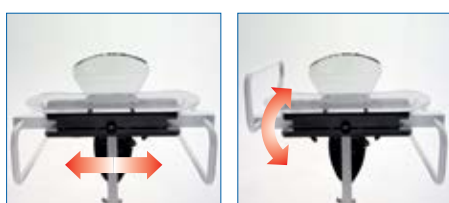

POSSIBLE ACCESSORIES:

AC0044 Back strap; AC0049 Lateral supports; AC0050 Lateral and back supports; AC0782 Long handles; AC0692 Anti-crush system; AC0693 Front support; AC0694 Front support with anti-crush system.

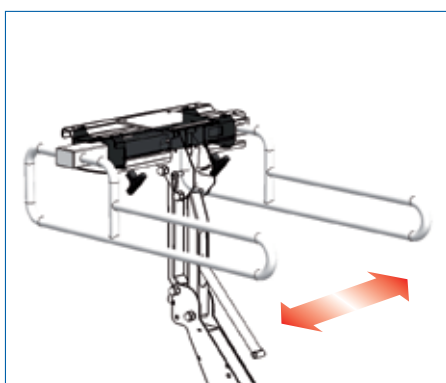

5 Long handles, adjustable by sliding

The main supporting frame is provided with side handles adjustable in width for better restraint and to better adapt to the anthropometric characteristics of the user. The adjustment of the width of the handles is done by sliding, and it is activated by a small lever which is also used for locking manually the position. Therefore the adjustment of width is done separately for each handle. The width between the two handles may vary from a minimum of 370 mm to a maximum of 580 mm. A special feature of these handles is that it is possible to apply on them several accessories for lateral and especially back restraint at lowback and cervical levels. Dimensions: Width 460 mm x Length/Depth 802 mm x Height 230 mm; Weight: 5,8 kg. Max. load: 140 kg.

POSSIBLE ACCESSORIES:

AC0702 Adjustable side supports; AC0703 Adjustable lateral back supports; AC0075 Locking device; AC0074 Back support; AC0076 Head support; AC0692 Anti-crush system; AC0693 Front support; AC0694 Front support with anti-crush system.



Standing frames Configuration guide

Position 10

ACCESSORIES FOR LATERAL SUPPORT

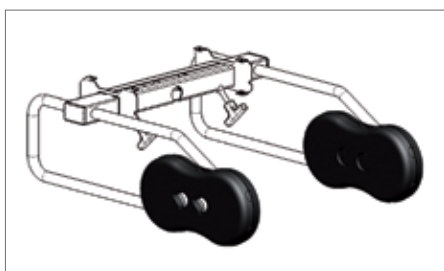

AC0049 LATERAL SUPPORTS

The user encounters a larger contact surface and a softer lateral restraint. The internal structure of the element is made of metal with a foam rubber covering. This is a very shock-absorbing and easy to clean material. The lateral supports can be applied only on short handles, i.e. options 2 and 4 of position 10 of the article code. They are fixed and cannot be adjusted in depth on the handles. They are provided in pairs.

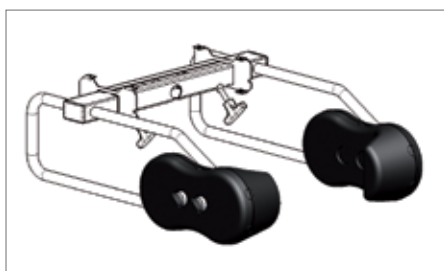

AC0050 LATERAL AND BACK SUPPORTS

The user encounters a larger contact surface and a softer lateral restraint. The internal structure of the element is made of metal with a foam rubber covering. This is a very shock-absorbing and easy to clean material. The lateral supports can be applied only on short handles, i.e. options 2 and 4 of position 10 of the article code. They are fixed and cannot be adjusted in depth on the handles. They are provided in pairs.

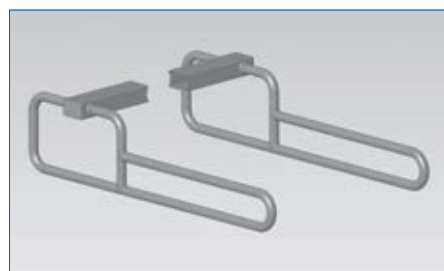

AC0782 LONG HANDLES

If the configuration choice includes short side handles, adjustable in width by sliding (referring to option 4 of position 10 of the article code), it is possible to request accessory longer handles. This possibility allows to have a greater flexibility and more possibilities of stabilization as well as side and back restraint of the user when needed by applying the other accessories available just for long handles.

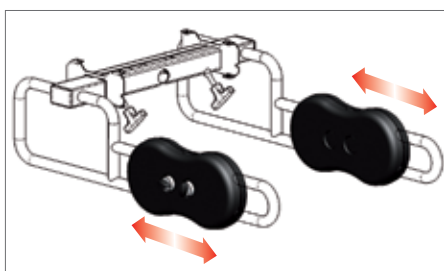

AC0702 ADJUSTABLE LATERAL SUPPORTS

The user encounters a larger contact surface and a softer lateral restraint. The internal structure of the element is made of metal with a foam rubber covering. This is a very shock-absorbing and easy to clean material. The lateral supports can be applied only on long handles, i.e. options 3 and 5 of position 10 of the article code. The supports can be adjusted in depth on the handles. They are provided in pairs.

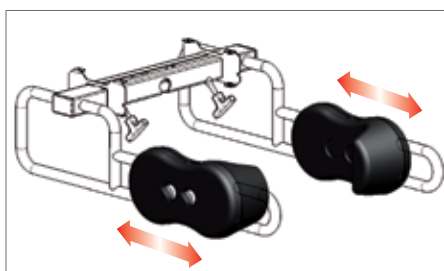

AC0703 ADJUSTABLE LATERAL/BACK SUPPORTS

The user encounters a larger contact surface and a softer lateral restraint. The internal structure of the element is made of metal with a foam rubber covering. This is a very shock-absorbing and easy to clean material. The lateral supports can be applied only on long handles, i.e. options 3 and 5 of position 10 of the article code. The supports can be adjusted in depth on the handles. They are provided in pairs.



NOTE: For adjusting the width of the handles, see the description of possible options as they are described in position 10 of configuration code.

Position 10

ACCESSORIES FOR BACK SUPPORT



AC0783 BACK STRAP

When necessary, it is possible to apply easily a strap for a greater restraint at back level once the person has reached the upright position. This strap is applied by an assistant, and its function is mainly to prevent risk movements as a result of an improper control of the trunk by the user. It is available in one size only.

Position 10 ACCESSORIES FOR BACK SUPPORT

In more complicated situations, and when it is more difficult to stay in an upright position, the carers can intervene with a specific structure to be mounted on the side handles. This configuration is possible only when long handles are mounted on, adjustable by sliding (regarding to position 10, option code 4). Therefore, the related supports to be used with the added structure are adjustable according to the carer, to obtain the best posture and comfort for the user.

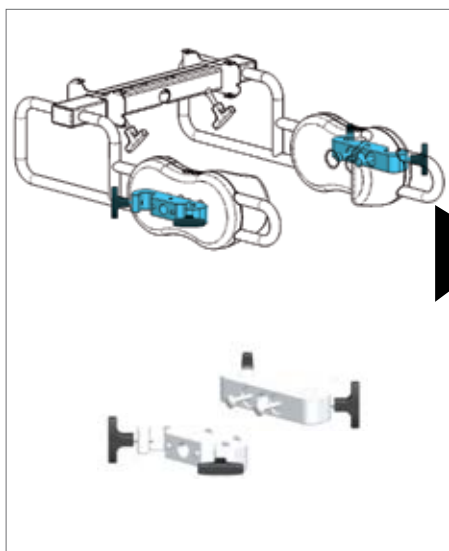

AC0075 LOCKING DEVICES

These are devices which can be applied onto the extra lateral supports, accessory code AC0702 or AC0703. They provide an extra back restraint. In such case, it is necessary to request other specific accessories. They are provided in pairs.

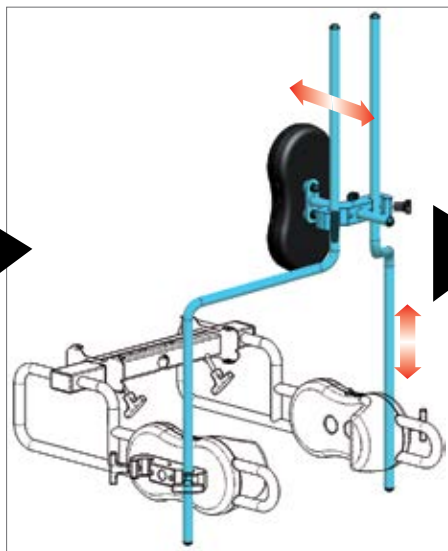

AC0074 BACK SUPPORT

It is composed by a metal structure which is inserted in the corresponding locking devices accessory code AC0075 which have been previously applied onto the side supports. In this way, the structure becomes a whole with the standing frame and it can be adjusted altogether in height. Furthermore, it allows to adjust a back support in height and depth. The back support is soft made of rubber foam.

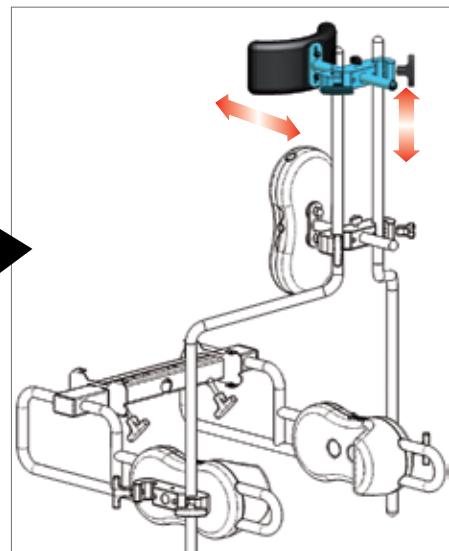

AC0076 HEAD SUPPORT

Whenever the standing frame is provided with a back support structure accessory code AC0074 it is possible to integrate this structure as well with an extra support for the head of the user. This is adjustable in height and depth and it has the same constructive characteristics as the other supports, i.e. soft resistant material easy to clean.

Position 10 ACCESSORIES FOR FRONT SUPPORT

If the user has a good control of the trunk, he does not need any front support. On the contrary, it may hinder the use of the service tray during carrying out of various activities, as well as limit the resting of the forearms. Nevertheless, the upper part of the aid is designed for holding a possible front support as an accessory. Various front supports are available, even with an anti-crushing safety system by contact.



AC0692 ANTI-CRUSHING SAFETY SYSTEM

This is a round bar with a stainless steel plate with a light coating of plexiglass. This device has the function of preventing the crushing, and it stops the lifting whenever it gets in contact with the user. It is adjustable in depth in seven available pre-set positions, and up to a maximum of 84 mm. The minimum variation is at least 12 mm. Dimensions: Width 128 mm x length 396 mm x height 88 mm.



AC0693 FRONT SUPPORT

This broad support is useful whenever there is not a proper control of the trunk by the user. It is adjustable in depth in seven available pre-set positions up to a maximum of 84 mm. The minimum variation is at least 12 mm. Dimensions: Width 300 mm x length 385 mm x height 258 mm.



AC0694 ANTI-CRUSHING FRONT SUPPORT

This broad support is useful whenever there is not a control of the trunk by the user. It is adjustable in depth in seven available pre-set positions up to a maximum of 84 mm. The minimum variation is at least 12 mm. This support includes the anti-crushing safety with stopping of the lifting by contact with the user. Dimensions: Width 300 mm x length 396 mm x height 258 mm.

Standing frames Configuration guide

Position 11

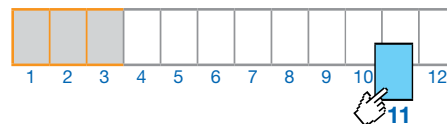

THE STRUCTURE – UPPER PART

The main front frame of Chinesport standing frames can hold the user in several ways while coming up to the upright position. Therefore, among the possible choices, there is also the possibility to help those who are very weak, bent forward, little cooperative, and who need a greater support for the trunk starting from the sitting position. On the other hand, it is also important and may be enough that the main frame allows a greater support and side restraint with handles adjustable in width.



2 Dynamic structure, with adjustable handles

The upper supporting frame offers an anterior support for the trunk of the user since he is in a starting sitting position, until the transfer onto the standing frame is completed. The service tray, the possible thoracic support and the side handles accompany the user while lifting. These support elements move along with the person while adopting the upright position. This action is even thus more simplified and the structure is reassuring while accompanying dynamically the user along to reach the upright position. Furthermore, the structure can be configured with adjustable handles in width for a greater lateral support and restraint (see available options position 10 of the configuration code). Dimensions: Width 464 mm x Depth 430 mm x Height 504 mm; Weight: 6,8 kg. Max. load: 140 kg.

POSSIBLE ACCESSORIES:

AC0692 Anti-crush safety system; AC0693 Front support; AC0694 Front support with anti-crush safety system.

STANDING FRAMES



STANDING COMBINED WITH GAMING

The structure of our standing frames, with a central column for stabilizing the upright position, allows to easily detect and register the movements of the user in space by means of distance detecting technologies while doing rehabilitation in upright position. Some experiments are currently implemented at hospital facilities.

Position 11

THE STRUCTURE – UPPER PART

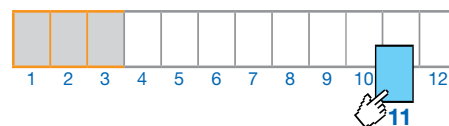

6



3 Fixed structure, with fixed handles

The upper support structure is adjustable both in height and depth, by sliding a stainless steel tube on a guide. The placing device is operated by a gas spring and a screw handle with the further function of safety lock. Handles – service tray, once they have been adjusted, they keep a static point of reference for the user while being lifted. Handles are not adjustable and the internal width is 540 mm. Dimensions: Width 464 mm x Depth 364 mm x Height 632 mm; Weight: 8,9 Kg. Max. load: 140 kg.

POSSIBLE ACCESSORIES:

AC0692 Anti-crush safety system; AC0693 Front support; AC0694 Front support with anti-crush safety system.



4 Fixed structure, with adjustable handles

The upper support structure is adjustable both in height and depth, by sliding a stainless steel tube on a guide. The placing device is operated by a gas spring and a screw handle with the further function of safety lock. Handles – service tray, once they have been adjusted, they keep a static point of reference for the user while being lifted. As a difference from option 3 all the available accessories of the handles that can be adjusted in width can be applied onto it. (see previous position 10 of the configuration code). Dimensions: Width 464 mm x Depth 428 mm x Height 632 mm; Weight: 10,4 kg. Max. load: 140 kg.

POSSIBLE ACCESSORIES:

AC0692 Anti-crush safety system; AC0693 Front support; AC0694 Front support with anti-crush safety system.



Standing frames Configuration guide

Position 12

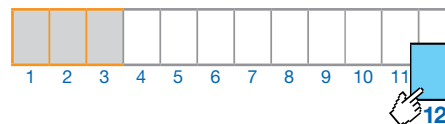

THE SERVICE TRAY

The service tray or table is an important part of a standing frame and it is very practical as the user may use it as a support for placing objects while he is in the upright position. Here we present several suggestions of service trays with different dimensions and made of different materials trying to meet the preferences of the users, in case of home use, or the preferences of the carers at a rehabilitation center. The service tray is shaped and can be tilted so that it is possible to allow a grip by the user while actively researching his upright position. Any service tray can be mounted or replaced easily.

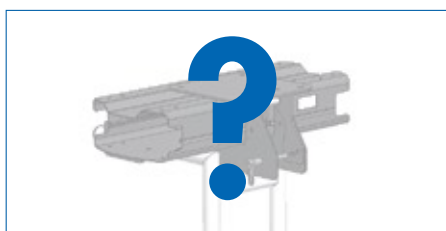

N Without service tray

None of the options presented in this position of product code is of any interest. The standing frame is, therefore, available without any service tray, which allows complete freedom when personalizing the frame concerning shape and materials.

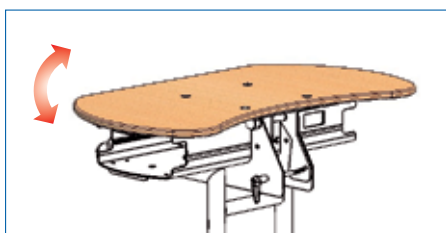

A Wooden service tray – medium size

Made of birch plywood with transparent matt paint coating, of medium dimensions. Tilt is adjustable in four pre-established positions, with a difference of 5 degrees for each position and up to 20 degrees positive. Dimensions: width 600 mm x Depth 340 mm x Thickness 12 mm. Weight: 1,4 kg.

POSSIBLE ACCESSORIES: AC0766.W? Padding medium tray, AC0765 ABS tray with raised edges - medium, 01608 Hand grip, 01609 Hand-wrist grip.

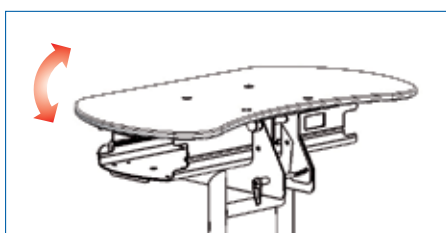

B Polyethylene service tray – medium size

Made of high-density polyethylene, antibacterial, of medium dimensions. Tilt is adjustable in four pre-established positions, with a difference of 5 degrees for each position and up to 20 degrees positive. Dimensions: width 600 mm x Depth 340 mm x Thickness 12 mm. Weight: 2 kg.

POSSIBLE ACCESSORIES: AC0766.W Padding medium tray, AC0765 ABS tray with raised edges - medium, 01608 Hand grip, 01609 Hand-wrist grip.

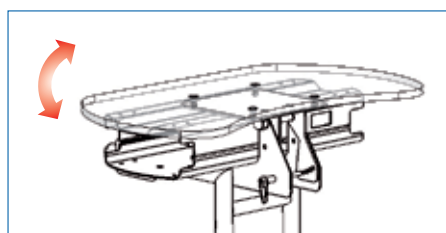

C Plexiglass service tray - medium size

Made of transparent plexiglass, of medium dimensions. Tilt is adjustable in four pre-established positions, with a difference of 5 degrees for each position and up to 20 degrees positive. Dimensions: width 600 mm x Depth 340 mm x Thickness 12 mm. Weight: 2,4 kg.

POSSIBLE ACCESSORIES: AC0766.W? Padding medium tray, AC0765 ABS tray with raised edges - medium, 01608 Hand grip, 01609 Hand-wrist grip.

Position 12

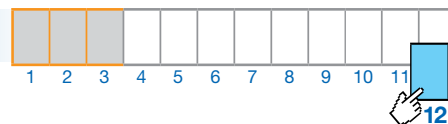

6

THE SERVICE TRAY

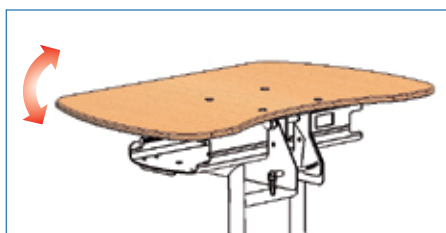

E Wooden service tray – large size

Made of birch plywood with transparent matt paint coating, of large dimensions. Tilt is adjustable in four pre-established positions, with a difference of 5 degrees for each position and up to 20 degrees positive. Dimensions: Width 680 mm x Depth 430 mm x Thickness 12 mm. Weight: 2,1 kg.

POSSIBLE ACCESSORIES: AC0767.W? Padding large tray, AC0764 ABS tray with raised edges - large, 01608 Hand grip, 01609 Hand-wrist grip.

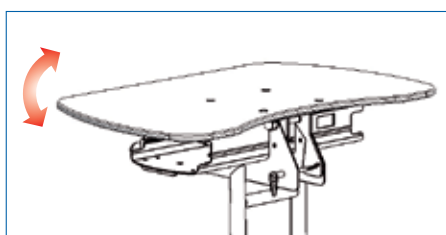

F Polyethylene service tray – large size

Made of high-density polyethylene, antibacterial, of large dimensions. Tilt is adjustable in four pre-established positions, with a difference of 5 degrees for each position and up to 20 degrees positive. Dimensions: width 680 mm x Depth 430 mm x Thickness 12 mm. Weight: 3 kg.

POSSIBLE ACCESSORIES: AC0767.W? Padding large tray, AC0764 ABS tray with raised edges - large, 01608 Hand grip, 01609 Hand-wrist grip.



G Plexiglass service tray - large size

Made of transparent plexiglass, of large dimensions. Tilt is adjustable in four pre-established positions, with a difference of 5 degrees for each position and up to 20 degrees positive. Dimensions: width 680 mm x Depth 430 mm x Thickness 12 mm. Weight: 3,6 kg.

POSSIBLE ACCESSORIES: AC0767.W? Padding large tray, AC0764 ABS tray with raised edges - large, 01608 Hand grip, 01609 Hand-wrist grip.

SERVICE TRAY ACCESSORIES

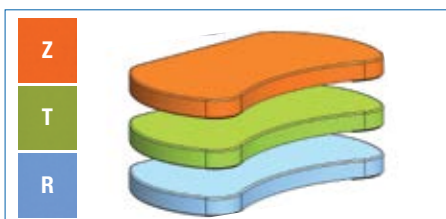

AC0766.W ? MEDIUM SERVICE TRAY PADDING
Padded upholstery of the medium tray. Available in three colours. Please, complete the accessory code with the upholstery colour.



AC0765 MEDIUM ABS TRAY
Extra tray made of ABS with raised edges to be applied on top of the chosen standard medium service tray. Easily removable for cleaning.



01608 HAND GRIP
For those with less upper torso stability. The patient only needs one or two support-points for stability.

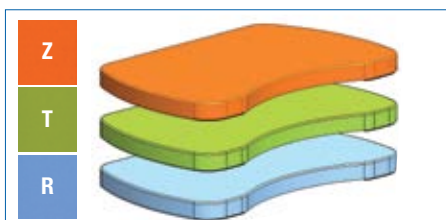

AC0767.W ? LARGE SERVICE TRAY PADDING
Padded upholstery of the large tray. Available in three colours. Please, complete the accessory code with the upholstery colour.



AC0764 ABS LARGE TRAY
Extra tray made of ABS with raised edges to be applied on top of the chosen standard large service tray. Easily removable for cleaning.



01609 HAND-WRIST GRIP
With a supporting cushion and a velcro wrist band which allows the positioning of the hand safely.

Pos. 4 The base structure

- 2** For independent mobility, compact base
- 3** For independent mobility, easy access

Pos. 5 The footplates

- 0** Without footplates
- 1** Wooden footplates, positionable with screws
- 2** Metal footplates, adjustable without tools

Pos. 6 The knee supports

- 1** Anatomic supports, adjustable
- 2** Softer supports, adjustable
- 3** Softer supports, adjustable only in height

Pos. 7 The height of the structure

- A** Adjustable by gas spring
- B** Adjustable by electric motor

Pos. 8 Lift

- 3** Totally assisted, by electric motor

Pos. 9 Lift support

- 2** Fixed long seat
- 3** Short seat, adjustable in depth
- 4** Removable long seat

Pos. 10 The side handles

- 2** Short handles, adjustable by rotation
- 3** Long handles, adjustable by rotation
- 4** Short handles, adjustable by sliding
- 5** Long handles, adjustable by sliding

Pos. 11 The structure - upper part

- 2** Dynamic structure, adjustable handles

Pos. 12 The service tray

- N** Without service tray
- A** Wooden service tray – medium size
- B** Polyethylene service tray – medium size
- C** Plexiglass service tray - medium size
- E** Wooden service tray – large size
- F** Polyethylene service tray – large size
- G** Plexiglass service tray - large size

A	V	3					3				2
1	2	3	4	5	6	7	8	9	10	11	12

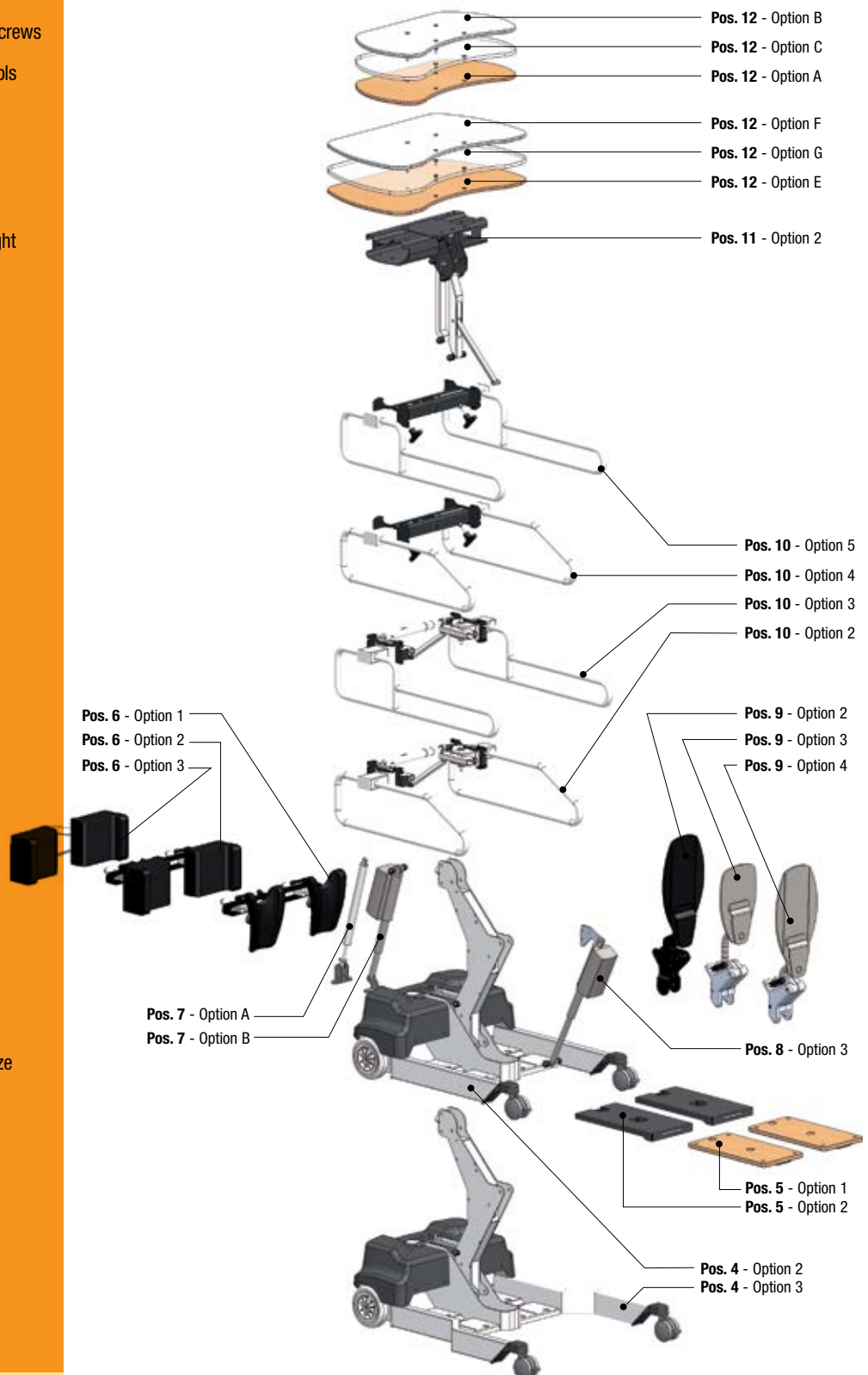

For further information regarding options and accessories, please see previous paragraphs.

A V 3 2 2 1 B 3 3 4 2 C
 1 2 3 4 5 6 7 8 9 10 11 12

Example of product configuration

This device enables the user to assume and maintain an upright position, and to move around indoors independently without assistance from a carer. The user is lifted into a standing position by means of an electric motor operated by hand control, while the movement of the service tray accompanies the user along the lifting operation. The service tray has an anti-crushing safety system sensor which can be activated at any time by the user (accessory code AC0692). The aid is provided with a two-motor electric drive which allows unaided movement by using a joystick. The footplates are fitted with adjustable heel rests (accessory code AC0686). The adjustment of the height of the main structure, directly involving the setting of the knee supports and the service tray is motorized and operated by hand control. The trunk is held at both sides by two handles which can be tilted and adjusted in width. Back support is provided by a standard seat adjustable in depth. The whole system of adjustments allows to better suit the whole aid accordingly to the anthropometrical characteristics of the user. For further information, please refer to the section on options, accessories and adjustments. Weight: 70 kg. Maximum load: 140 kg

(Ex code AV 23 2420 - Struzzo 2420)



The model in the picture has the AC0686 and AC0692 accessories on.

THERAPEUTIC INDICATIONS

“With proper distinctions and the necessary attention regarding each specific case, it is considered that this product can be aimed at those suffering from spinal cord illnesses or injury, paraplegia, multiple sclerosis, Parkinson’s disease or by muscular pathologies, muscular dystrophy, as well as for those who find it difficult to stand up, for example the elderly”.

Training Course “Technologies for Autonomy” (Università Cattolica di Milan and Don Gnocchi Foundation) School year 1999-2000. Carlo Marchesini’s paper.

END USER

This aid allows any careful paralytic person, with enough control of one hand, to enjoy the pleasure of moving around at fast pace speed while keeping an upright position, as well as having the access to high shelves and an ease of movement in narrow passages similar to normal. The upright position is reached by means of a motorized seat and also aided by the handle-thoracic support-service tray system which comes down when the patient is sitting down and offers a front support for the trunk of the patient when still sitting and holds him when coming up. If the person is not cooperative while transferring from the wheelchair onto the aid, it is possible to use a shaped pocket (accessory AC0048) which allows the seat to go under the anti-decubitus cushion without having to lift the user from the wheelchair. The shaped pocket can be used only with the long seat.



TECNICAL DATA

ARTICLE CODE	AV3 221 B33 42C
Handle-thoracic support group	movable-can be lifted
Electric servo-assisted lift	electric
Structure height adjustment	electric
Overload protection	acoustic
Parking brake	on back castors
Speed of movement (joystick)	Max 2.5 Km/h (adjustable)
Frame height from ground	31 mm
Maximum climbable step	20 mm
Maximum climbable slope	2 degrees
Operation time (lift/transfer)	Normal use 3-4 days (2h 30m continuous use while moving around)
Average recharging battery time	8 hours
Battery charging level	multi-color display on joystick
Auto off	as standard
Fault diagnostics and maintenance	on display
Anti-crushing safety system	not as standard (accessory)

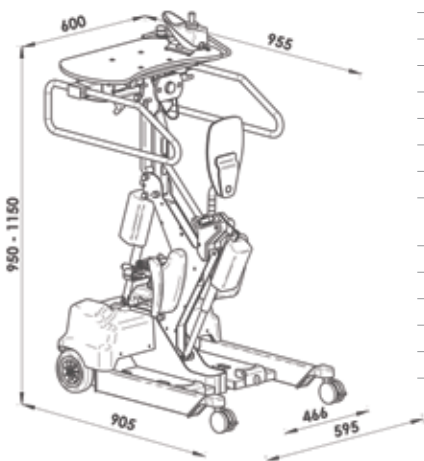

ACCESSORIES:

- AC0685 FIXED HEEL RESTS
- AC0047 FOOT STRAPS
- AC0014 LEGS STRAPS
- AC0543 PADDING FOR SHORT SEAT
- AC0544 PADDING FOR LONG SEAT
- AC0690 REMOVABLE LONG SEAT
- AC0048 POCKET FOR LONG SEAT
- AC0782 LONG HANDLES
- AC0049 LATERAL SUPPORTS
- AC0050 LATERAL-BACK SUPPORTS
- AC0702 ADJUSTABLE LATERAL SUPPORTS
- AC0703 ADJUSTABLE LATERAL-BACK SUPPORTS
- AC0783 BACK STRAP
- AC0075 LOCKING DEVICES
- AC0074 BACK SUPPORT
- AC0076 HEAD SUPPORT
- AC0692 ANTI-CRUSHING SAFETY SYSTEM
- AC0693 FRONT SUPPORT
- AC0694 ANTI-CRUSHING FRONT SUPPORT
- 01608 HAND GRIP
- 01609 HAND-WRIST GRIP
- AC0766.W? COLOURED PADDING FOR MEDIUM SERVICE TRAY
- AC0765 MEDIUM ABS SERVICE TRAY

A	V	3	1					3			2
1	2	3	4	5	6	7	8	9	10	11	12

Pos. 4 The base structure

- 1 For aided mobility

Pos. 5 The footplates

- 0 Without footplates
- 1 Wooden footplates, positionable with screws
- 2 Metal footplates, adjustable without tools

Pos. 6 The knee supports

- 1 Anatomic supports, adjustable
- 2 Softer supports, adjustable
- 3 Softer supports, adjustable only in height

Pos. 7 The height of the structure

- A Adjustable by gas spring
- B Adjustable by electric motor

Pos. 8 Lift

- 3 Totally assisted, by electric motor

Pos. 9 Lift support

- 2 Fixed long seat
- 3 Short seat, adjustable in depth
- 4 Removable long seat

Pos. 10 The side handles

- 2 Short handles, adjustable by rotation
- 3 Long handles, adjustable by rotation
- 4 Short handles, adjustable by sliding
- 5 Long handles, adjustable by sliding

Pos. 11 The structure - upper part

- 2 Dynamic structure, adjustable handles

Pos. 12 The service tray

- N Without service tray
- A Wooden service tray – medium size
- B Polyethylene service tray – medium size
- C Plexiglass service tray - medium size
- E Wood service tray – large size
- F Polyethylene service tray – large size
- G Plexiglass service tray - large size

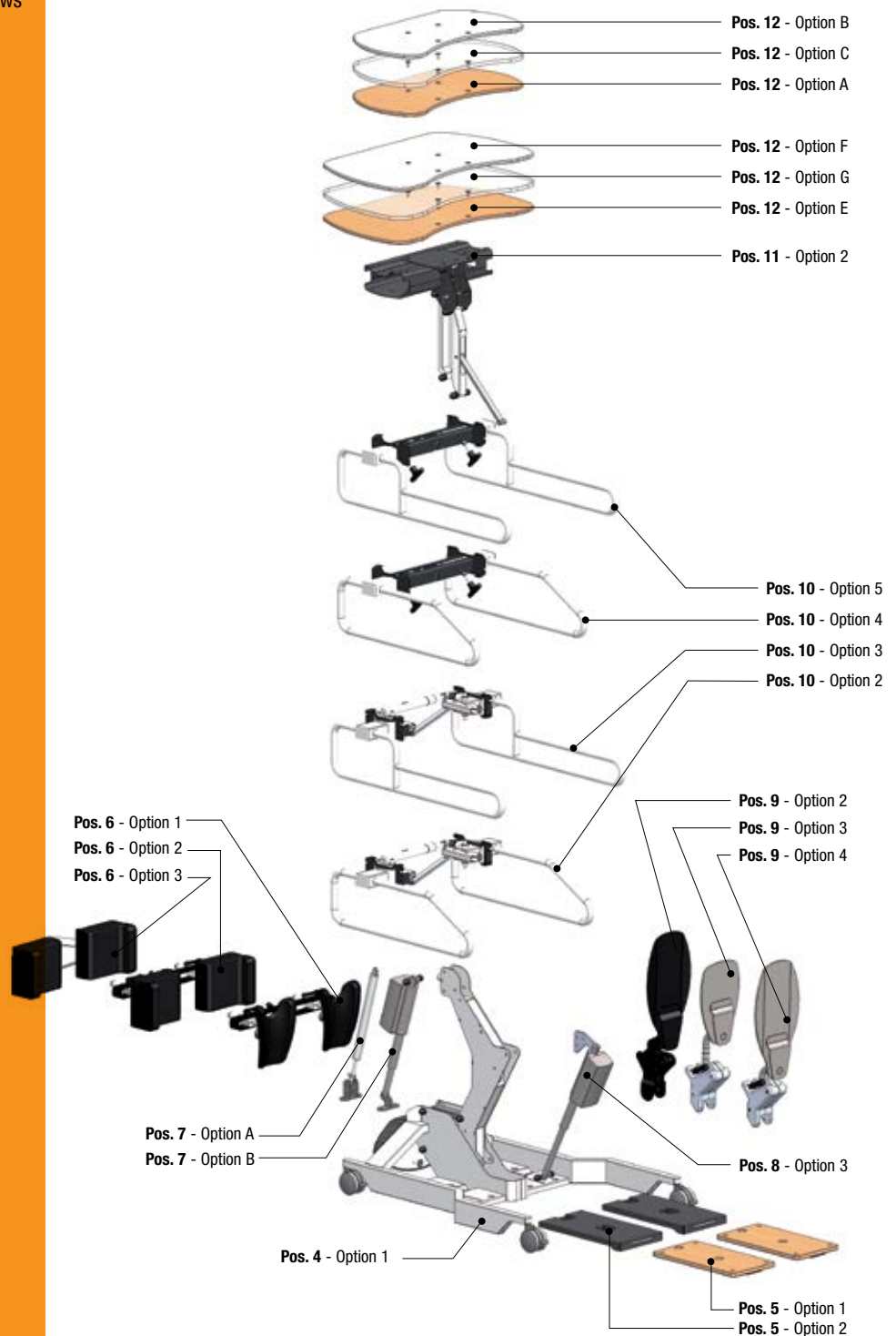

For further information regarding options and accessories, please see previous paragraphs.

A V 3 1 2 1 B 3 3 4 2 C
 1 2 3 4 5 6 7 8 9 10 11 12

Example of product configuration

This device allows the user to assume and maintain an upright position, and to move around indoors independently without assistance from a carer. The user is lifted into a standing position by means of an electric motor operated by hand control, while the movement of the service tray accompanies the user along the lifting lift. The service tray has an anti-crushing safety sensor which can be activated at any time by the user. The aid is provided with four wheels who allows an aided mobility. The footplates are completed with adjustable heelrests (AC0686). The adjustment of the height of the main structure, directly involving the setting of the knee supports and the service tray is motorized and operated by hand control. The trunk is held at both sides by two handles which can be adjusted in width by sliding and tilted. Back support is provided by a standard seat adjustable in depth. The whole system of adjustments allows to better suit the whole aid accordingly to the anthropometric characteristics of the user. For further information, please refer to the section on options, accessories and adjustments. Weight: 53 kg. Maximum load: 140 kg

(Ex code AV 14 2420 - EASY UP 2420)

The model in the picture has the AC0686 accessory on.



6

END USER

It can be the ideal model when there are several users during one day and when among these there are very weak patients, bent forward and not so cooperative ones, as well as those who suffer if overloaded at hip and knee levels. Furthermore, it reduces the work effort on behalf of the carer. Lift is done by starting from the electrically motorized seat, but it is aided by the handle-service tray group, which is low and close to the patient when sitting and which can offer a front support for the patient starting from that position and then is a valid restrain during the lift, being it horizontal while coming to the upright position along with the seat. If the person is not capable of cooperating during the transfer from the wheelchair onto the standing frame a shaped pocket can be used (Accessory AC0048 not included) which allows the seat to go under the anti-decubitus cushion without having to lift the user from the wheelchair. The shaped pocket can be used only with the long seat.



FOR FURTHER EASE ACCESSIBILITY



TECHNICAL DATA

ARTICLE CODE	AV3 121 B33 42C
Handle-thoracic support group	movable-can be lifted
Electric servo-assisted lift	electric
Structure height adjustment	electric
Overload protection	acoustic and on display
Parking brake	individual on four castors
Speed of movement (joystick)	not measured
Frame height from ground	31 mm
Maximum climbable step	not measured
Maximum climbable slope	not measured
Operation time (lift)	With a user weighing 140 Kg and fully charged batteries, 30 cycles of lifting aprox.
Average recharging battery time	6-8 hrs
Battery charging level	multi-color display
Auto off	as standard
Fault diagnostics and maintenance	on display
Anti-crushing safety system	not as standard (accessory)

ACCESSORIES:

- AC0685 FIXED HEEL RESTS
- AC0047 FOOT STRAPS
- AC0014 LEGS STRAPS
- AC0543 PADDING FOR SHORT SEAT
- AC0544 PADDING FOR LONG SEAT
- AC0690 REMOVABLE LONG SEAT
- AC0048 POCKET FOR LONG SEAT
- AC0782 LONG HANDLES
- AC0049 LATERAL SUPPORTS
- AC0050 LATERAL-BACK SUPPORTS
- AC0702 ADJUSTABLE LATERAL SUPPORTS
- AC0703 ADJUSTABLE LATERAL-BACK SUPPORTS
- AC0783 BACK STRAP
- AC0075 LOCKING DEVICES
- AC0074 BACK SUPPORT
- AC0076 HEAD SUPPORT
- AC0692 ANTI-CRUSHING SAFETY SYSTEM
- AC0693 FRONT SUPPORT
- AC0694 ANTI-CRUSHING FRONT SUPPORT
- 01608 HAND GRIP
- 01609 HAND-WRIST GRIP
- AC0766.W? COLOURED PADDING FOR MEDIUM SERVICE TRAY
- AC0765 MEDIUM ABS SERVICE TRAY

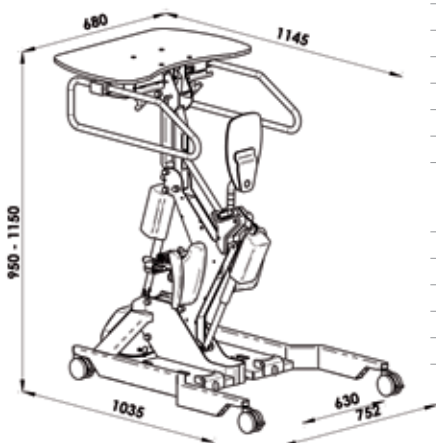

STANDING FRAMES

A	V	3	1	1					1	3	
1	2	3	4	5	6	7	8	9	10	11	12

Pos. 4 The base structure

- 1 For aided mobility
- 2 For independent mobility, compact base
- 3 For independent mobility, easy access

Pos. 5 The footplates

- 0 Without footplates
- 1 Wooden footplates, positionable with screws
- 2 Metal footplates, adjustable without tools

Pos. 6 The knee supports

- 1 Anatomic supports, adjustable
- 2 Softer supports, adjustable
- 3 Softer supports, adjustable only in height

Pos. 7 The height of the structure

- A Adjustable by gas spring
- B Adjustable by electric motor

Pos. 8 Lift

- 0 Unaided lift, manual
- 2 Partially assisted, by gas spring
- 3 Totally assisted, by electric motor

Pos. 9 Lift support

- 1 No support
- 2 Fixed long seat
- 3 Short seat, adjustable in depth
- 4 Removable long seat
- 5 Harness

Pos. 10 The side handles

- 1 Base handles, not adjustable

Pos. 11 The structure - upper part

- 3 Fixed structure, fixed handles

Pos. 12 The service tray

- N Without service tray
- A Wooden service tray – medium size
- B Polyethylene service tray – medium size
- C Plexiglass service tray - medium size
- E Wooden service tray – large size
- F Polyethylene service tray – large size
- G Plexiglass service tray - large size

For further information regarding options and accessories, please see previous paragraphs.

